

Models DLN-300D
DLN-300A

NAPKIN MAKE & PLACE SYSTEM

(Automated Napkin Converting)

The DLN-300 Napkin Machine System is a fully automated napkin folding and placing system.

The DLN-300D is a dedicated system with self-drive. Change parts are available for a choice of cut-off lengths from 10" to 17".

The DLN-300A model adds the electronic napkin length and tuck position adjustment feature with self-drive.

The system is designed to maintain low linear tension on the paper stock, reducing the chance of web break. Cross machine fold capability employs low pressure air jet tucking.

The outfeed rolls, which control the placement, are cantilevered from one side of the frame to allow o-ring changing without disassembly. Also, they raise easily to allow immediate access for maintenance.



Exclusive Features:

- Speeds up to 400 cycles per minute
- Size options up to 17" x 17"
- Make and place into GPS wrapping machines
- Proven design, rugged construction, great accuracy
- High efficiency air tucking
- High quality product



GEORGE GORDON ASSOCIATES, INC.

COMPREHENSIVE PACKAGING SYSTEMS



MODELS: DLN-300D/DLN-300A

NAPKIN MACHINE SYSTEM

Models:

- DLN-300D: Self-drive system
- DLN-300A: Self-driven, electronically adjustable napkin length

Features:

- Linear and cross folding
- Knife and anvil cutting
- Placement
- UL approved

Options:

- Folds and places plastic bags from pre-sealed tubing
- Embossing: several patterns available
- Printing: 1 or 2 colors
- Electronically adjustable
- CE version available

Technical Data

Electrical: 230 VAC, 60 Hz, single phase

Current: Approximately 30 Amps

Compressed Air: 80 PSIG @ 8cfm

Production: Up to 400 cycles per minute

Product size: 10" x 10", up to 17" x 17"

Head roll with is 3.5" and will accommodate 1.5" to 2.5" folded webs

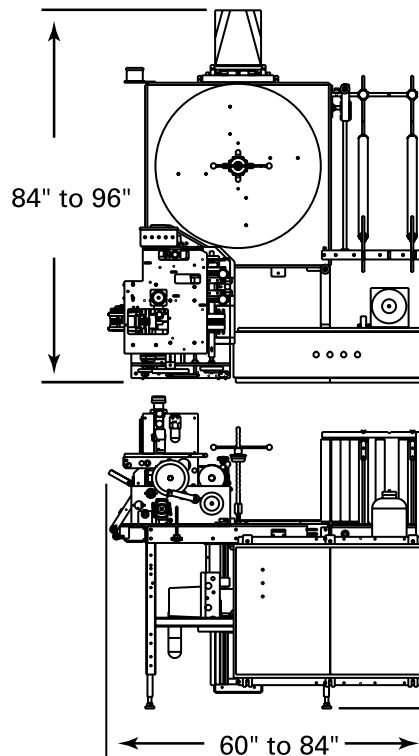

The napkin system is a fully automated, completely adjustable, napkin folding system. Available with a 36" table or a 48" table for longer run time.

Order Number

XXX-XXXX-X-XX-X-XX-XXX

DLN-300D: Self-driven Napkin System

DLN-300A: Adjustable self-driven Napkin System

-1: One cross fold on napkins from 10" to 17"

-2: Two cross folds on napkins from 10" to 17"

-36: Holds roll of napkins up to 36" diameter

-48: Holds roll of napkins up to 48" diameter

-E: Embosser option

-0: No embosser option

-P1: 1 color flexographic print option

-P2: 2 color flexographic print option

-00: No print option

-125: 1 1/8" - 1 3/8" linear fold width

-200: 1 7/8" - 2 1/8" linear fold width

-225: 2 1/8" - 2 3/8" linear fold width

George Gordon Associates, Inc.

12 Continental Boulevard

Merrimack, NH 03054

Call 603-424-5204

FAX: 603-424-9031

E-mail: sales@ggapack.com

Web: www.ggapack.com