

Model VWC-008/VWC-009

VERTICAL WRAPPING SYSTEM

(Side By Side Packaging System)

The Model VWC side by side Vertical Wrapping System is designed to individually wrap cutlery or similarly shaped items in a package sealed on four sides. Each wrapping system is capable of wrapping items of various styles within the package size limits.

The Vertical Wrapping System receives items placed side-by-side in the conveyor trough, and is engineered for operator efficiency and high production rates. The system transfer wheel deposits each item directly into the film "V", eliminating potential transfer problems.

Film is fed from two unwind stands, with each film roll forming one side of each package. This enables approximately one full shift of operation without a film roll change.



Exclusive Features:

- Double unwind stand
- Precision tension control
- Side by side conveyor
- Precision temperature control
- Automatic hot roll pull away to prevent web melting
- Efficient shear cutting with carbide blades



GEORGE GORDON ASSOCIATES, INC.

COMPREHENSIVE PACKAGING SYSTEMS



Model VWC-008/VWC-009 Vertical Wrapping System

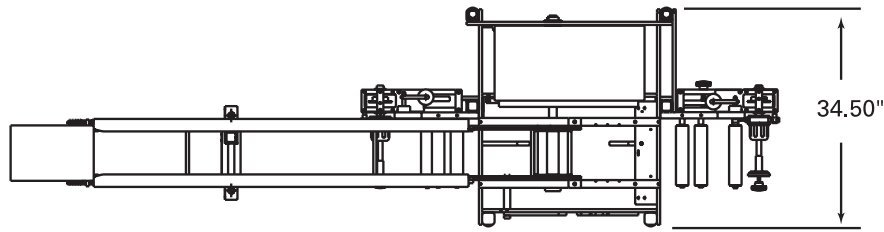

Its small size and reliability make the side by side vertical wrapper ideal for dedicated applications where space is limited.

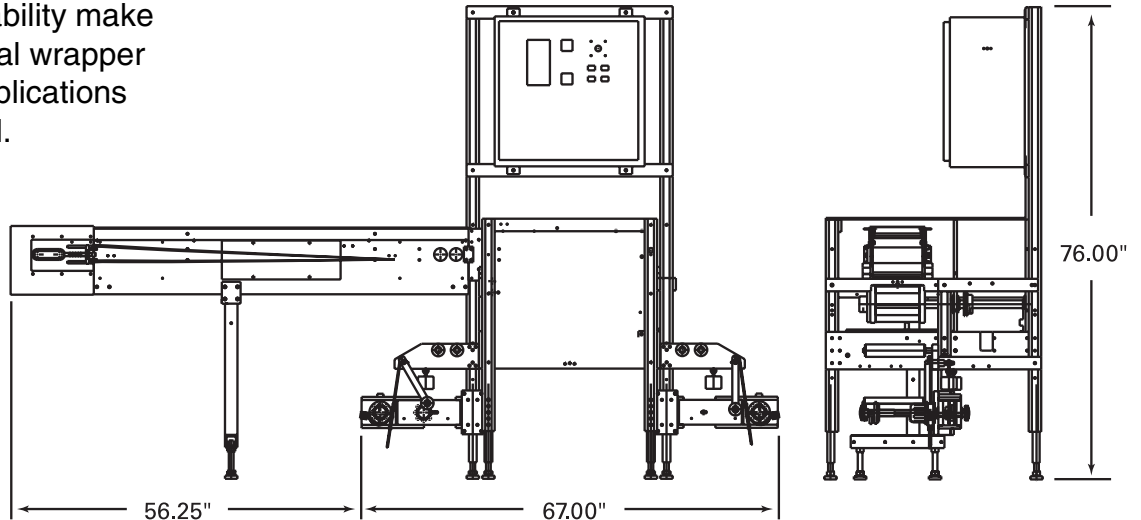

Models:

- VWC-008: 8 inch wrapper
- VWC-009: 9 inch wrapper

Features:

- Double unwind stand
- Precision tension control
- Side by side conveyor
- Precision temperature control
- Web break detection

Options:

- Conveyor length from 5' to 20'
- Batch counter
- Perforation option
- Vacuum option
- Brush assembly

George Gordon Associates, Inc.

12 Continental Boulevard
Merrimack, NH 03054
Call 603-424-5204
FAX: 603-424-9031
E-mail: sales@ggapack.com
Web: www.ggapack.com

Technical Data

Production: From 60 up to 240 cycles per minute

Current: Approximately 20 Amps

Compressed Air: 1 cfm @ 80 PSIG

Electrical: 230 VAC, 60 Hz, three phase

Package: Dedicated size

VWC-008, 2.6" x 8"

VWC-009, 3.6" x 9"

Order Number

XXX-XXX-X.X-X-X

VWC: Model Vertical Wrapping System

- 008: 8 inch wrapper

- 009: 9 inch wrapper

- 2.6: 2.6" package width

- 3.6: 3.6" package width

- V: With vacuum

- 0: Without vacuum

- #: Number indicates total conveyor length